

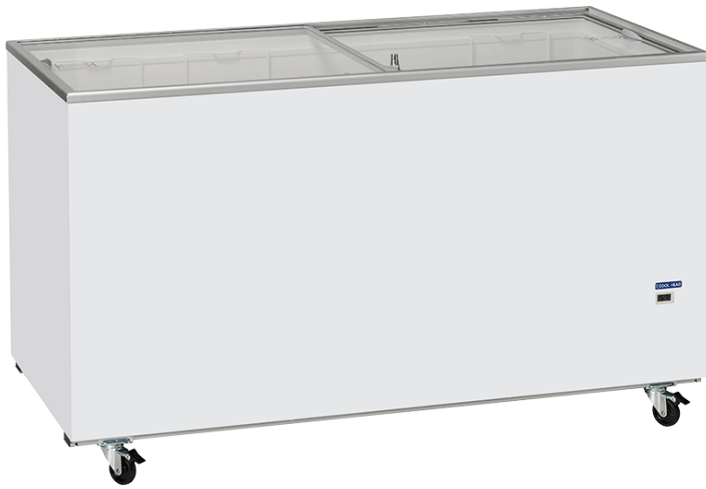

RoHS



Data sheet

Depth	635 mm
Height	890 mm
Width	1555 mm
Inner depth	515 mm
Inner height	645 mm
Inner width	1430 mm
Noise level	57.3 dB(A)
KW/24h	2.39 Kw
Capacity	500 L
Consumption	191 W
Net Weight	85 Kg
Temperature	-12° ~ -22°C

Technical features

- 500 Lt. Chest freezer with sliding glass top
- White coated steel for external and internal
- Static cooling
- Manual defrost
- Digital thermometer
- Foaming Agent Cyclopentane (60mm per side)
- Double tempered safety glass
- Handle on the glass frame
- Lock fitted as standard
- Basket included (N.3 Pcs)
- N.4 Castor (N.2 in the front with brake)

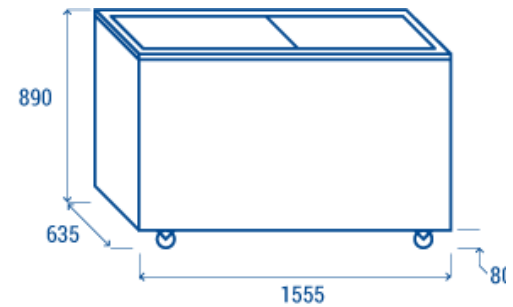

Castor included in the packaging (To be assembled)



Digital thermometer



Lock fitted as standard



Basket included



Top view of the unit