



RoHS



## Data sheet

Depth	540 mm
Height	685 mm
Width	610 mm
Inner depth	430 mm
Inner height	540 mm
Inner width	500 mm
Noise level	45 dB
KW/24h	3.84 Kw
Capacity	90 L
Consumption	213 W
Net Weight	49 Kg
Temperature	-15°C ~ -20°C

## Technical features

- 90 Lt. Upright freezer
- White coated steel for internal and external side
- Static cooling
- Manual defrost
- Foaming Agent Cyclopentane (55mm per side)
- Removable Gasket
- Interior LED light
- Triple heated safety tempered glass
- Self closing door
- Lock fitted as standard
- Adjustable shelves: 3 Pcs
- N.4 Adjustable feet

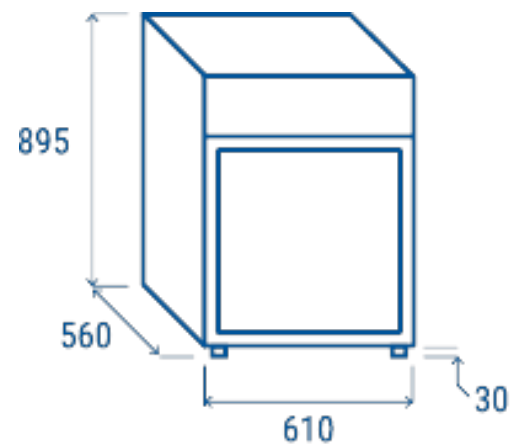

Lock fitted as standard