



RoHS



Data sheet

Depth	670 mm
Height	838 mm
Width	598 mm
Inner depth	477 mm
Inner height	647 mm
Inner width	493 mm
Noise level	40 dB(A)
KW/24h	1.659 Kw
Capacity	200 L
Consumption	170 W
Net Weight	38 Kg
Temperature	-23°C ~ -18°C

Technical features

- 200 Lt. Freezer upright
- S/S external cabinet, thermoformed internally
- Static cooling: fixed evaporator shelves (N.3 Layers)
- Manual defrost
- Foaming Agent Cyclopentane (50mm per side)
- Digital Thermostat
- Removable Gasket
- Reversible door
- Lock and main switch fitted as standard
- Stainless steel external handle
- N.2 Adjustable feet + N.2 Rollers at the back

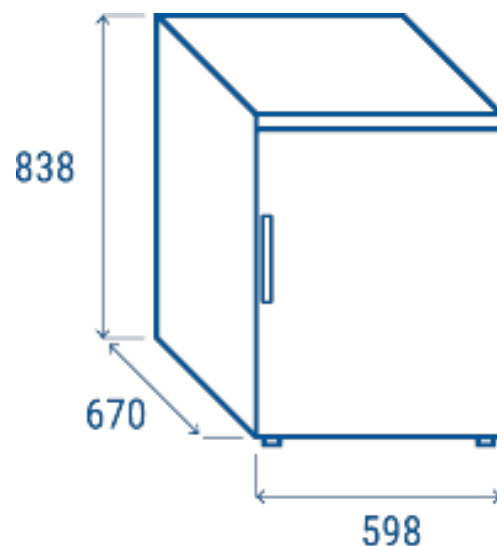

Main switch, digital thermostat and door lock fitted as standard



Fixed evaporator shelves



External cylindric handle in stainless steel (Steel color for X Version)