

# UNIBLOCK BX

La tipologia costruttiva dei gruppi **BX** ne consente l'impiego all'esterno senza alcuna particolare protezione contro gli agenti atmosferici. L'applicazione è del tipo a parete ma con telaio appoggiato a terra. La carrozzeria delle unità **BX** è in lamiera di acciaio verniciata a polvere epossidica. La caratteristica principale della carrozzeria è data dalla presenza di pannelli frontali apribili per facilitare l'accesso all'impianto frigorifero. I compressori sono di tipo semiermetico alternativo funzionanti con refrigerante R404A. L'impiantistica inoltre prevede l'utilizzo di tutti i dispositivi necessari al buon funzionamento in tali condizioni. Per garantire la minima dispersione di calore in cella durante a fase di sbrinamento, i condotti di distribuzione dell'aria dell'evaporatore vengono forniti completi di sistema di chiusura automatico. Per raggiungere il soffitto della cella i condotti dell'aria evaporatore sono disponibili in varie altezze. I gruppi **BX** sono disponibili oltre che per le normali applicazioni in media e bassa temperatura, anche in esecuzione speciale denominata "Polivalente", P, che consente l'utilizzo della cella sia in media che in bassa temperatura. La serie denominata "C", è equipaggiata con compressori doppio stadio alternativi semiermetici ed è adatta per tunnel di congelamento.

Le unità sono complete di:

- ricevitore di liquido
- spia passaggio liquido
- valvola solenoide di linea
- valvola termostatica per l'espansione del refrigerante
- sbrinamento, di tipo elettrico, completamente automatico
- scambiatore di calore
- quadro elettrico (protezione IP55) con strumentazione di controllo e comando di tipo elettromeccanico
- pressostato ventilatore condensatore
- resistenza preriscaldamento compressore
- pressostati di minima e massima pressione
- monitor di tensione

Sulla porta esterna sono visibili le lampade di segnalazione blocchi e funzionamento

*The type of construction of the **BX** units enables their use outside without any particular protection against the atmospheric agents. The installation is the trough wall mounting but the chassis is on the floor.*

*The casing of the **BX** units is made from epoxide powder painted steel sheet.*

*The main characteristic of the body is the presence of openable front panels facilitating access to the cooling system.*

*The reciprocating semihermetic compressors are working with refrigerant R404A.*

*The system also provides for the use of all devices necessary for good operation in those conditions.*

*In order to guarantee minimum heat loss in the cold room during the defrost stage, the air distribution ducts of the evaporator are supplied complete with automatic closing system.*

*To reach the top of the cold room the evaporator air ducts are available in various heights.*

*The **BX** units are available in the standard applications in medium and low temperature, and also in special execution called "Polivalente" P (Multipurpose) enabling use of the cold room both in medium and in low temperature.*

*The series called "C", is equipped with two-stage reciprocating semihermetic compressors and is suitable for freezing tunnels.*

*The units are complete with:*

- liquid receiver
- liquid sightglass
- line solenoid valve
- thermostatic valve for expansion of the refrigerant
- fully automatic, electric type defrost
- heat exchanger
- electrical panel (IP55 protection) with electromechanical control
- condenser fan pressure switch
- compressor crankcase heating
- minimum and maximum pressure switches
- voltage monitor

*The door has blocking and status signalling lamps.*

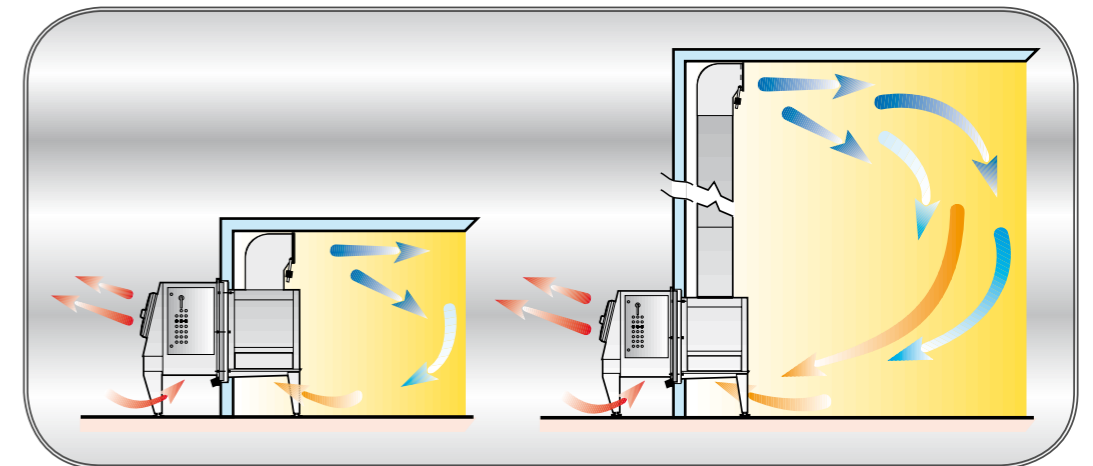

## OPZIONI

- variatore elettronico di velocità delle ventole condensatore
- condensazione ad acqua
- pannello remoto di comando (per una o più macchine montate sulla stessa cella)
- tensione di alimentazione diversa dallo standard

## OPTIONALS

- condenser fans electronic speed variator
- water condensing
- remote control panel (for one or more machines assembled on the same cold room)
- different supply voltage

## VANTAGGI

- montaggio estremamente veloce
- riduzione di costi e tempi di installazione
- elevata efficienza in dimensioni compatte

## ADVANTAGES

- extremely fast assembly
- reduced installation costs and times
- high efficiency in compact dimensions



Codice Code		MBX260T01F		MBX360N01F		MBX360T01F	
Potenza nominale Nominal Power		18,4 kW S		24,5 kW S		29 kW S	
Refrigerante Refrigerant		R404A		R404A		R404A	
Tensione Voltage		400/3N~/50		400/3N~/50		400/3N~/50	
Assorbim. nom. Nominal absorption		20,7 kW* 39,5 A		31,8 kW* 71,4 A		36,1 kW* 79,6 A	
Sbrinamento Defrost		EL		EL		EL	
Portata d'aria cond. Air flow cond.		22300 m <sup>3</sup> /h		34000 m <sup>3</sup> /h		33300 m <sup>3</sup> /h	
Portata d'aria evap. Air flow evap.		20500 m <sup>3</sup> /h		31600 m <sup>3</sup> /h		30900 m <sup>3</sup> /h	
Freccia d'aria Air throw		39 m**		40 m**		39 m**	
Massa Mass		1400 kg		2075 kg		2120 kg	
Tc °C	Ta °C	Pf Watt	V100 m <sup>3</sup>	Pf Watt	V100 m <sup>3</sup>	Pf Watt	V100 m <sup>3</sup>
10	20	64344	1984	86046	2731	96637	3105
	25	60879	1867	81356	2568	91353	2918
	30	57419	1751	76685	2406	86074	2732
	35	53950	1635	71990	2244	80782	2548
	40	50457	1519	67226	2082	75457	2363
	45	46927	1402	62351	1916	70082	2179
5	20	56900	1733	75815	2376	85520	2713
	25	53890	1633	71815	2238	80924	2553
	30	50877	1533	67701	2098	76307	2393
	35	47825	1432	63479	1955	71628	2232
	40	44699	1329	59153	1809	66845	2069
	45	41463	1223	54728	1661	61917	1902
0	20	50300	1514	66892	2070	75712	2372
	25	47686	1427	63307	1949	71696	2234
	30	45008	1339	59599	1824	67553	2093
	35	42266	1249	55790	1696	63311	1949
	40	39460	1158	51904	1567	58997	1804
	45	36589	1065	47965	1436	54637	1658
-5	20	43815	1300	58328	1781	66067	2042
	25	41490	1224	55261	1679	62466	1920
	30	39108	1146	52048	1572	58737	1795
	35	36688	1068	48738	1462	54952	1668
	40	34248	989	45378	1351	51179	1543
	45	31808	911	42018	1241	47488	1421

Codice Code		BBX260N01F		BBX260T01F		BBX360N01F		BBX360T01F	
Potenza nominale Nominal Power		22 kW S		29,4 kW S		36,7 kW S		44,1 kW S	
Refrigerante Refrigerant		R404A		R404A		R404A		R404A	
Tensione Voltage		400/3N~/50		400/3N~/50		400/3N~/50		400/3N~/50	
Assorbim. nom. Nominal absorption		23,8 kW* 52,7 A		28,1 kW* 60,8 A		40,7 kW* 88,6 A		43,7 kW* 97,5 A	
Sbrinamento Defrost		EL		EL		EL		EL	
Portata d'aria cond. Air flow cond.		22800 m <sup>3</sup> /h		22300 m <sup>3</sup> /h		34000 m <sup>3</sup> /h		33300 m <sup>3</sup> /h	
Portata d'aria evap. Air flow evap.		22400 m <sup>3</sup> /h		21800 m <sup>3</sup> /h		33600 m <sup>3</sup> /h		32800 m <sup>3</sup> /h	
Freccia d'aria Air throw		42 m**		41 m**		42 m**		41 m**	
Massa Mass		1410 kg		1570 kg		2120 kg		2130 kg	
Tc °C	Ta °C	Pf Watt	V100 m <sup>3</sup>	Pf Watt	V100 m <sup>3</sup>	Pf Watt	V100 m <sup>3</sup>	Pf Watt	V100 m <sup>3</sup>
-15	20	41231	1487	48866	1820	65323	2576	74056	2998
	25	38502	1371	45779	1684	61079	2376	69299	2766
	30	35852	1258	42713	1550	56857	2180	64414	2533
	35	33212	1148	39645	1419	52631	1988	59551	2305
	40	30510	1037	36548	1288	48376	1799	54856	2090
	45	27678	922	33399	1156	44064	1609	50480	1892
-20	20	35017	1224	42347	1535	56658	2172	63625	2496
	25	33026	1141	39741	1423	53064	2008	59850	2319
	30	30849	1051	37073	1310	49378	1843	55728	2129
	35	28522	956	34332	1195	45599	1676	51514	1938
	40	26083	858	31507	1078	41729	1509	47464	1758
	45	23569	757	28589	959	37765	1339	43834	1599
-25	20	29841	1009	36353	1280	48759	1816	54866	2090
	25	28227	944	34324	1194	45935	1691	51759	1949
	30	26395	870	32053	1100	42796	1554	48364	1798
	35	24402	790	29626	1001	39469	1412	44741	1638
	40	22304	708	27129	900	36081	1268	40950	1475
	45	20159	623	24651	800	32760	1129	37050	1309

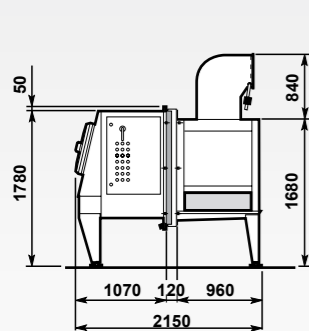

**BX 260  
BX 360**

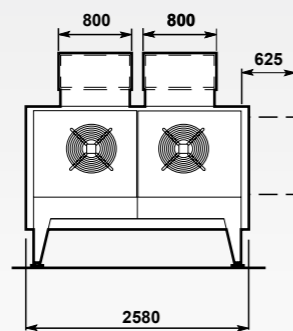

**BX 260**

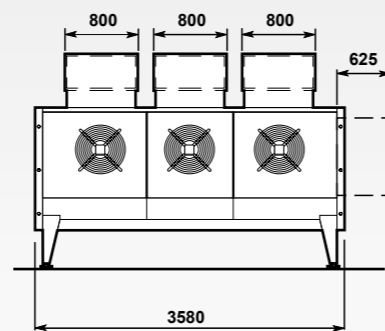

**BX 360**

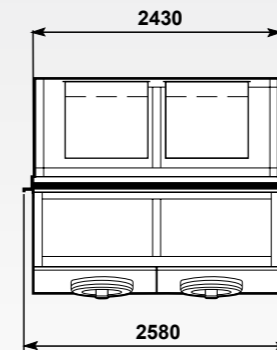

**BBX 260**

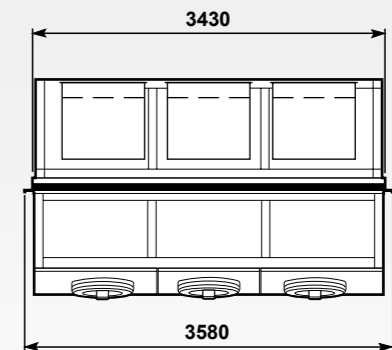

**BBX 360**



Codice Code		PBX260T001F		PBX360T001F	
Potenza nominale Nominal Power		44,1 kW S		58,8 kW S	
Refrigerante Refrigerant		R404A		R404A	
Tensione Voltage		400/3N~/50		400/3N~/50	
Assorbim. nom. Nominal absorption		32 kW* 70,6 A		42,7 kW* 95,6 A	
Sbrinamento Defrost		EL		EL	
Portata d'aria cond. Air flow cond.		22300 m³/h		33300 m³/h	
Portata d'aria evap. Air flow evap.		21800 m³/h		32800 m³/h	
Freccia d'aria Air throw		41 m**		41 m**	
Massa Mass		2140 kg		2320 kg	
Tc °C	Ta °C	Pf Watt	V100 m³	Pf Watt	V100 m³
5	20	58635	1630	86552	2502
	25	54801	1513	81173	2331
	30	50967	1398	75860	2163
	35	47133	1282	70536	1997
	40	43298	1168	65125	1829
	45	39465	1054	59552	1658
0	20	52790	1452	77801	2224
	25	49180	1344	72803	2068
	30	45571	1236	67875	1915
	35	41962	1127	62934	1762
	40	38354	1021	57898	1608
	45	34744	915	52686	1450
-5	20	45524	1234	68639	1938
	25	42445	1142	64091	1797
	30	39428	1053	59613	1660
	35	36401	964	55123	1523
	40	33289	872	50540	1385
	45	30019	776	45783	1242
-15	20	48887	1821	71321	2864
	25	45447	1670	66983	2655
	30	42004	1520	62643	2449
	35	38562	1372	58304	2247
	40	35122	1228	53965	2049
	45	31688	1086	49626	1854
-20	20	43032	1565	63251	2478
	25	40007	1435	59377	2297
	30	36982	1306	55503	2119
	35	33958	1179	51629	1944
	40	30933	1055	47755	1771
	45	27907	931	43881	1601
-25	20	37142	1313	55171	2104
	25	34388	1197	51799	1951
	30	31837	1091	48329	1796
	35	29357	990	44731	1638
	40	26821	887	40977	1476
	45	24098	778	37040	1308



Codice Code		CBX260T301F		CBX260T401F		CBX260T501F		CBX360T001F	
Potenza nominale Nominal Power		22 kW DS		29,4 kW DS		36,7 kW DS		55 kW DS	
Refrigerante Refrigerant		R404A		R404A		R404A		R404A	
Tensione Voltage		400/3N~/50		400/3N~/50		400/3N~/50		400/3N~/50	
Assorbim. nom. Nominal absorption		20,1 kW* 48,4 A		25,5 kW* 59,3 A		28,3 kW* 65,1 A		42,5 kW* 97,7 A	
Sbrinamento Defrost		EL		EL		EL		EL	
Portata d'aria cond. Air flow cond.		22300 m³/h		22300 m³/h		22300 m³/h		33300 m³/h	
Portata d'aria evap. Air flow evap.		26900 m³/h		26900 m³/h		25900 m³/h		39000 m³/h	
Freccia d'aria Air throw		45 m**		45 m**		44 m**		44 m**	
Massa Mass		1450 kg		1660 kg		1700 kg		2570 kg	
Tev °C	Tcnd °C	Pf Watt	Pf Kcal/h	Pf Watt	Pf Kcal/h	Pf Watt	Pf Kcal/h	Pf Watt	Pf Kcal/h
-30	35	37114	31918	51474	44268	60450	51987	90675	77980
	40	36490	31381	48500	41710	59444	51122	89166	76683
	45	35811	30797	51792	44541	58340	50172	87510	75259
	50	35022	30119	46484	39976	57048	49061	85571	73591
	55	34068	29298	17707	15228	55475	47708	83213	71563
-35	35	31259	26883	43019	36996	50922	43793	76383	65689
	40	30776	26467	42236	36323	50130	43112	75194	64667
	45	30246	26012	41747	35902	49260	42364	73890	63545
	50	29609	25464	40622	34935	48216	41466	72324	62199
	55	28802	24770	37929	32619	46902	40336	70352	60503
-40	35	26125	22468	35889	30865	42553	36596	63830	54894
	40	25747	22142	35563	30584	41939	36068	62909	54102
	45	25327	21781	34617	29771	41250	35475	61875	53212
	50	24807	21334	34266	29469	40400	34744	60600	52116
	55	24130	20752	35724	30723	39304	33801	58956	50702
-45	35	21640	18610	29779	25610	35243	30309	52864	45463
	40	21343	18355	29256	25160	34767	29900	52151	44850
	45	21010	18069	29047	24980	34223	29432	51335	44148
	50	20587	17705	28222	24271	33534	28839	50300	43258
	55	20023	17220	25849	22230	32622	28055	48933	42082
-50	35	17734	15251	24386	20972	28889	24845	43334	37267
	40	17500	15050	24092	20719	28509	24518	42763	36776
	45	17251	14836	23684	20368	28093	24160	42140	36240
	50	16922	14553	23296	20035	27552	23695	41328	35542
	55	16448	14145	23059	19831	26794	23043	40191	34564

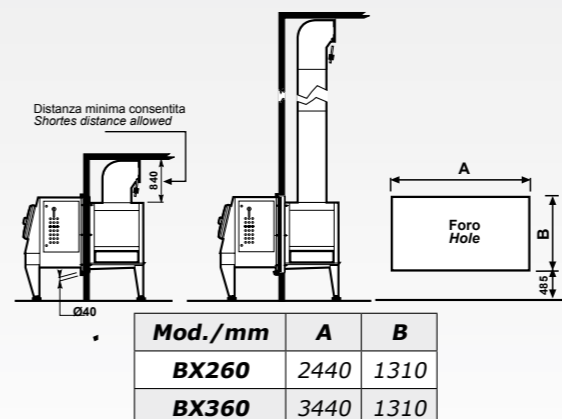

**Massa e misure imballi**  
**Packing mass and dimensions**

Mod./mm	C	D	E	Kg	Volume
BX260	2340	2730	1615	400	10,15
BX360	2340	3730	1615	460	14,09
C BX 260	2340	2730	1615	400	10,15
C BX 360	2340	3730	1615	460	14,09